

# Installation Instructions for 2-1/16" Fuel Pressure Gauge

## Before You Start

This gauge features peak recall, programmable high and low full dial warning and external warning output. Please read instructions completely before installing.

- **ALWAYS WEAR SAFETY GLASSES.**
- Install gauge only when engine is cool and ignition is off.
- Make sure all necessary tools, materials, and parts are on hand.
- Disconnect negative (-) battery cable before installing gauge.
- 2-1/16" gauge mounts in a 2-1/16" diameter hole.
- Make sure mounting location does not impair visibility or interfere with driving. Also check behind the mounting location for any wiring or components before drilling.

## Fig 1. Wiring Diagram

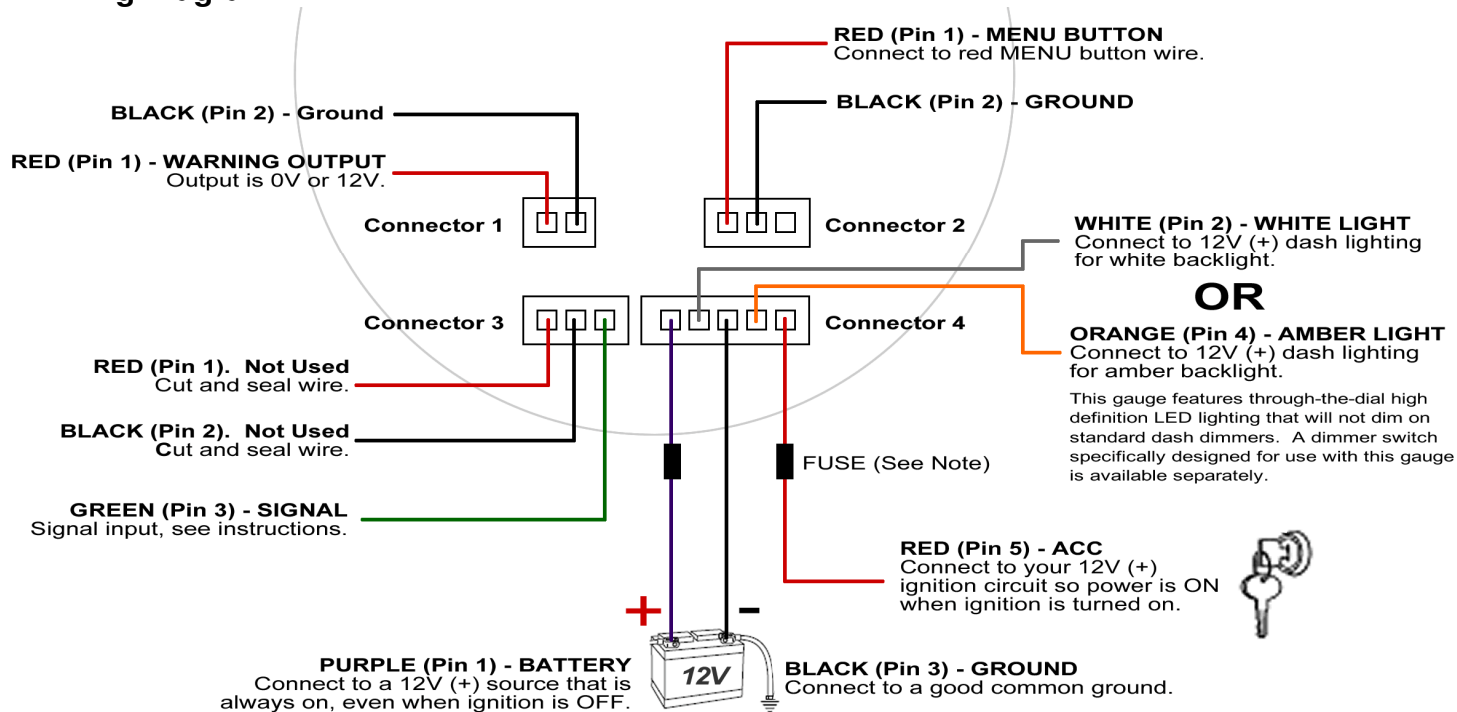

## Table 1. Wiring Summary

	Color	Pin	Connector	Notes
12V+ (Battery)	Purple	1	4	Connect to a 12V+ source that is always on, even when ignition is OFF (i.e. Battery +)
White Light	White	2	4	Connect to 12V+ dash lighting for white backlight.
Ground	Black	3	4	Connect to a good common ground.
Amber Light	Orange	4	4	Connect to 12V+ dash lighting for amber backlight.
12V+ ACC (Ignition)	Red	5	4	Connect to 12V+ ignition circuit so power is ON when ignition is turned on.
Red	Red	1	3	Not used. Cut and seal so no wire is exposed.
Black	Black	2	3	Not used. Cut and seal so no wire is exposed.
Signal	Green	3	3	Signal input, see Sender Installation below.
Menu Button +	Red	1	2	Connect to red MENU button wire.
Menu Button -	Black	2	2	Connect to black MENU button wire.
Not Used	Green	3	2	Cut and seal so no wire is exposed.
Warning Output +	Red	1	1	Normal operating mode: 0V output. Warning mode: 12V output.
Warning Output -	Black	2	1	

## Wiring

Use 20 AWG stranded or heavier wire for installation. Route wires away from any moving parts and hot engine components. Secure wires firmly along their route. **Cut and seal all unused wire connections.**

**Note:** As a safety precaution, the RED (Pin 5) and PURPLE (Pin 1) 12V+ connections should be fused. We recommend using a 1 Amp, 3 AG fast-acting type cartridge fuse.

## Lens Protective Film

The gauge comes with a soft protective plastic film on the lens. Remove the protective film when gauge installation is complete.

## Lens Cleaning

Some gauges come with an acrylic plastic lens. Do not use any chemicals or abrasives on an acrylic lens. To prevent scratching, caution must be used when cleaning. To clean, wipe lightly with a damp soft cloth.

## MENU Button Installation

Installation of the remote MENU button is only necessary if you want to use the RECALL and WARNING features of the gauge. Installation of the MENU button is NOT required if you do not wish to use the RECALL or WARNING features.

Mount the included MENU button in a location that is convenient. Connect the red wire from the button to Connector 2, Pin 1 (Red) and the black wire on the button to Connector 2, Pin 2 (Black). See Fig 1.

## Dimmable LED Lighting

This gauge features through-dial, high-definition LED lighting that will not dim when used with standard dash dimmers. A dimmer switch specifically designed for use with this gauge is available separately.

## Programming Full Dial Low Warning (WARN LO)

This gauge can be configured to show a full dial low warning (flashing amber backlight) when the gauge goes BELOW a specific value (i.e. pressure goes below 10psi).

1. To access WARN LO programming mode, press and hold the MENU button until the pointer moves to 25% scale (approx 1 second). Release the MENU button after the pointer has reached 25% scale.
2. After releasing the MENU button the pointer will move to the current low warning set point. Factory default is 0% scale (WARN LO deactivated).
3. To change the set point, press the MENU button repeatedly to move the pointer by 2% increments. Once the pointer reaches 100% scale, pressing the MENU button will decrease the pointer position by 2% increments.
4. Once the pointer indicates your desired low warning set point leave the MENU button untouched for 5 seconds. The low warning set point will be saved and the gauge will return to normal operating mode.

To turn the low warning OFF, repeat steps 1-4 above and change the low warning set point to 0% or 2% scale. Setting the low warning set point to 0% or 2% deactivates the low warning feature.

## Viewing and Clearing Peak Value (RECALL)

1. To view the peak value, press the MENU button one time.
2. To exit RECALL mode press the MENU button one time.
3. To clear the stored peak value press and hold the MENU button for 3 seconds while in RECALL mode.

## Sender Installation

It is recommended that the sender be remote mounted using a braided stainless steel fuel line (sold separately).

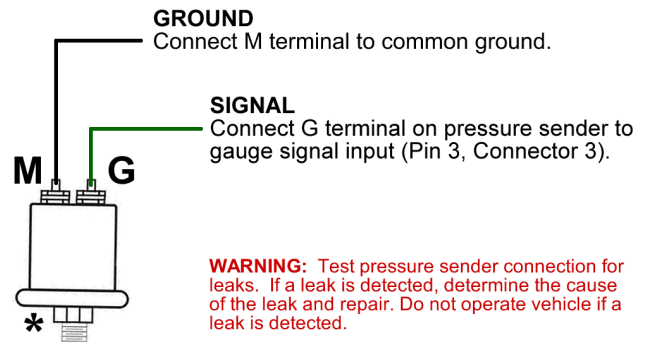

## Programming Full Dial High Warning (WARN HI)

This gauge can be configured to show a full dial high warning (flashing amber backlight) when the gauge goes ABOVE a specific value (i.e. pressure goes above 80psi).

1. To access WARN HI programming mode, press and hold the remote button until the pointer moves to 75% scale (approx 3 seconds). Note: the pointer will stop at 25% scale for approx 1 second (for WARN LO programming mode), continue holding the button until the pointer has reached 75% scale. Release the button after pointer has reached 75% scale.
2. After releasing the button the pointer will move to the current high warning set point. Factory default is 100% scale (WARN HI deactivated).
3. To change the set point, press the MENU button repeatedly to move the pointer by 2% increments. Once the pointer reaches 0% scale, pressing the MENU button will increase the pointer position by 2% increments.
4. Once the pointer indicates your desired high warning set point leave the MENU button untouched for 5 seconds. The high warning set point will be saved and the gauge will return to normal operating mode.

To turn the high warning OFF, repeat steps 1-4 above and change the high warning set point to 98% or 100% scale. Setting the high warning set point to 98% or 100% deactivates the high warning feature.

## External Warning Output

When warning mode is active the gauge outputs a 12V+ DC signal (500mA) on Pin 1 of Connector #1 (See Fig 1). This output is 0V when warning mode is not active. This output can be used to activate an external warning light or activate a switch.

Do not install Connector 1 if external warning output is not required.